



COL·LEGI D'ARQUITECTES, ARQUITECTES TÈCNICS
I ENGINYERS D'EDIFICACIÓ DE BARCELONA



La protecció solar en edificis terciaris i d'habitatges

1 d'octubre de 2015

WORKSHOP REHABILITACIÓ ENERGÈTICA

WORKSHOP REHABILITACIÓ ENERGÈTICA



COL·LEGI D'ARQUITECTES, ARQUITECTES TÈCNICS
I ENGINYERS D'EDIFICACIÓ DE BARCELONA



Proteccions solars en edificis d'oficines

P.T.A MÀLAGA



MODELO GM 200



488 UNT.
3200 M²

Arq. Salvador Moreno Peralta

www.storcn.ch



- Estalvi energètic
- Condicions particulars
- Sol·lució
- Auto gestió



www.storen.ch



- Condicions particulars
P.T.A de Màlaga



40° exterior

+



interior

52° sense protecció solar

=

24° temperatura de treball?



www.storen.ch

- Estalvi energètic

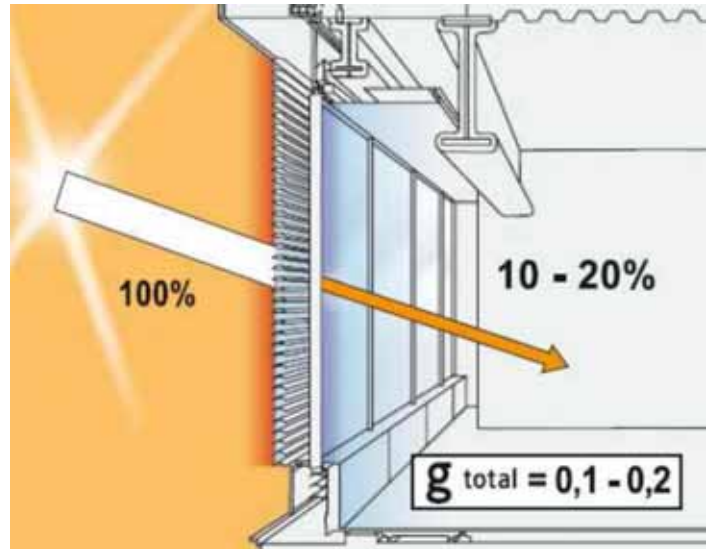

www.storen.ch

- Sol·lució

MODELO GM 200

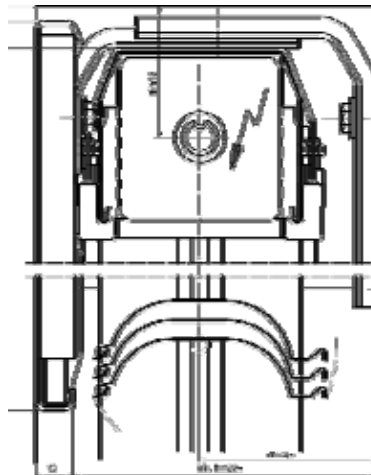

www.storen.ch



- Sol-lució.

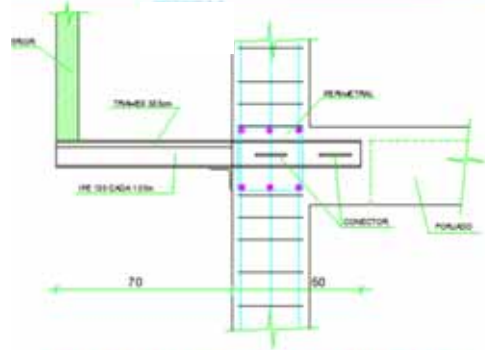
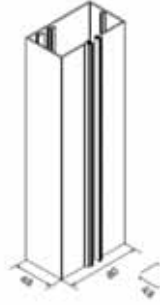

DETALLE DE ESTRUCTURA PARA APOYO DE PERSIANA

EJECUCION EN LA PARCELA "19-1" DEL PARQUE TECNOLÓGICO DE ANDALUCIA

P.T.A. (PARQUE TECNOLÓGICO ANDALUCIA)

www.storen.ch



- Sol-lució



www.storen.ch

- Sol·lució

MODELO GM 200

Dimensiones límite

	Individual		Acoplado	
	Manivela	Motor	Manivela	Motor
Altura de luz (hl) mín.	0,56 m	0,56 m	0,56 m	0,56 m
Altura de luz (hl) máx.	4,0 m	4,0 m	4,0 m	4,0 m
Anchura de construcción (bk) mín.	0,6 m	0,6 m		
Anchura de construcción (bk) máx.	2,8 m	2,8 m		
Área máxima	8 m ²	8 m ²	8 m ²	20 m ²
Número máximo			3	4

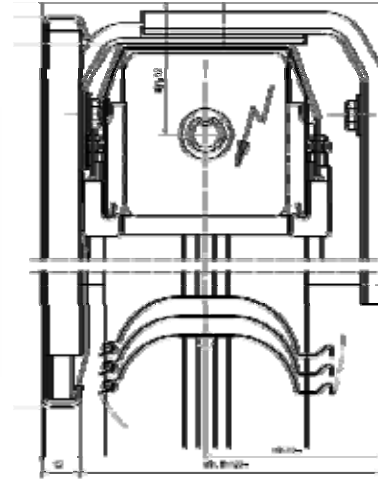

www.storen.ch

- Sol·lució

Aplicació de doble pell.

Separació de la façana 70 cm.



www.storen.ch

Vídeo demostració de producte



- Estalvi energètic



OFICINAS

INFORME SOBRE EL CONSUMO

EDIFICIO OFICINAS TIPO DE 5.000m²:
FACTURA DE ENERGIA DE 135.000€ / AÑO.

CONSUMO DE ENERGIA EN OFICINAS

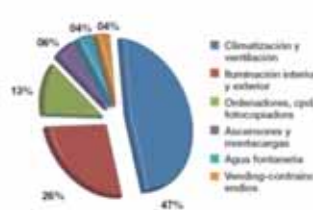

FACTURA ENERGÉTICA

CONSUMO DE LAS INSTALACIONES	FACTURA DE ENERGIA
Climatización y ventilación	64.000,00 €
Iluminación interior y exterior	35.000,00 €
Ordenadores, cpd, fotocopiadora	17.000,00 €
Ascensores y montacargas	8.000,00 €
Agua fontanera	6.000,00 €
Vending-contra incendios	5.000,00 €
TOTAL	135.000,00 €

www.storen.ch



- Estalvi energètic



ACCIONES Y COSTES PARA CONSEGUIR EL AHORRO

RANKING DE ACCIONES	COSTE €/m ²	AHORRO EST. (%) ¹	AHORRO ANUAL (€)	RETORNO INV. (AÑOS)	
1	Cambio de hábitos usuario	0	5%	6.750€	INMEDIATA
2	Cambios máquinas vending	0	5%	6.750€	INMEDIATA
3	Control presencia en iluminación	15	10%	13.500€	1-2 AÑOS
4	Control presencia en climatización	15	10%	13.500€	1-2 AÑOS
5	Gestion protección solar exterior	5	10 %	13.500€	2-3 AÑOS
6	Incluir protección solar exterior	100*	15%	20.250€	3-4 AÑOS
7	Integrar de las instalaciones	20	10%	13.500€	3-4 AÑOS
8	Cambios luminarias	30	15%	20.250€	5-6 AÑOS
9	Cambios máquinas climatización	250	15%	20.250€	10-11 AÑOS
10	Cambios ascensores	UD.	5%	6.750€	MAS 10 AÑOS
11	Reforma integral de fachada	600*	25%	27.000€	MAS 10 AÑOS

¹Porcentaje de ahorro potencial estimado con respecto al coste de la unidad de consumo a la que se refiere.

www.storen.ch



- Costos d'aplicació m²

Model GM 200 = 208€ (Projecte P.T.A)

Model VR 90 = 140€ (Alternativa amb funcionalitat similar)

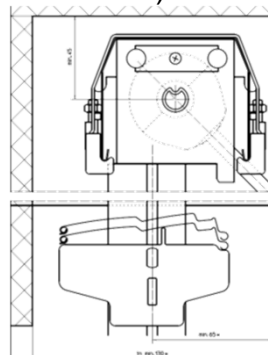
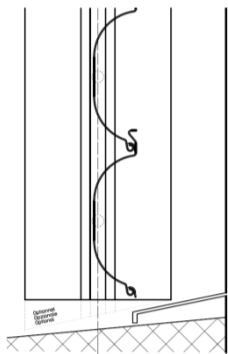

www.storen.ch

Sistemes d'autogestió no inclosos.



www.storen.ch



www.storen.ch



- Estalvi energètic.
- Habitabilitat.
- Control de llum.
- Productivitat.
- Auto gestió integral.



www.storen.ch



www.storen.ch

Josep.fito@storen.ch

Tel: 675 32 60 60